

DP200 Amphibious Excavator



DP200 Amphibious Excavator

- For dredging and dewatering
- Completely self propelled
- Able to work safely on soft terrain such as swamp, wet land and shallow water
- Able to working continuously even in bad weather i.e. raining day
- Modular in design for ease of transportation and shipping
- After-sales service and support



www.dredge-pump.com

Email Address: enquiry@dredge-pump.com

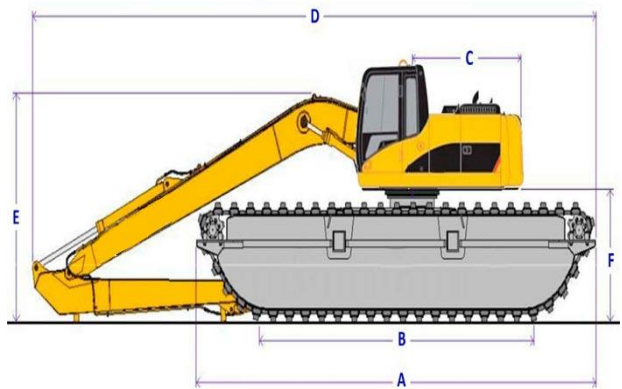
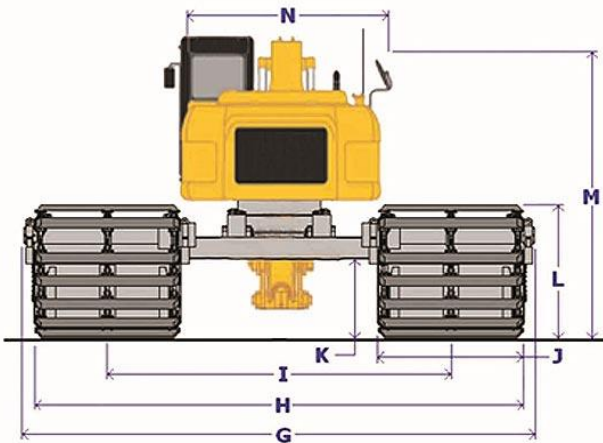

Specification

20 ton Class Excavator

Arm Type : Standard arm

Max Depth : 5.38 m

Undercarriage Dimension : L9.3m × W1.6m × 2m

Operation Weight : 32ton

Track Shoe Bar : 66sets

Optional Equipment

Dredging Pump

- Capacity : up to 860 m³/hour

- Head : up to 42 m

Both Side Cutterhead for Pump

Water Jet-Ring

Dredging Hose

Dewatering System



www.dredge-pump.com

Email Address: enquiry@dredge-pump.com