

Dredging Pontoon



- Transportable, lightweight and robust allows for rapid mobilization and demobilization
- Provides a stable work environment
- Facilitates flexible workplace options
- Constructed to international shipbuilding standards



www.dredge-pump.com

Email Address: enquiry@dredge-pump.com

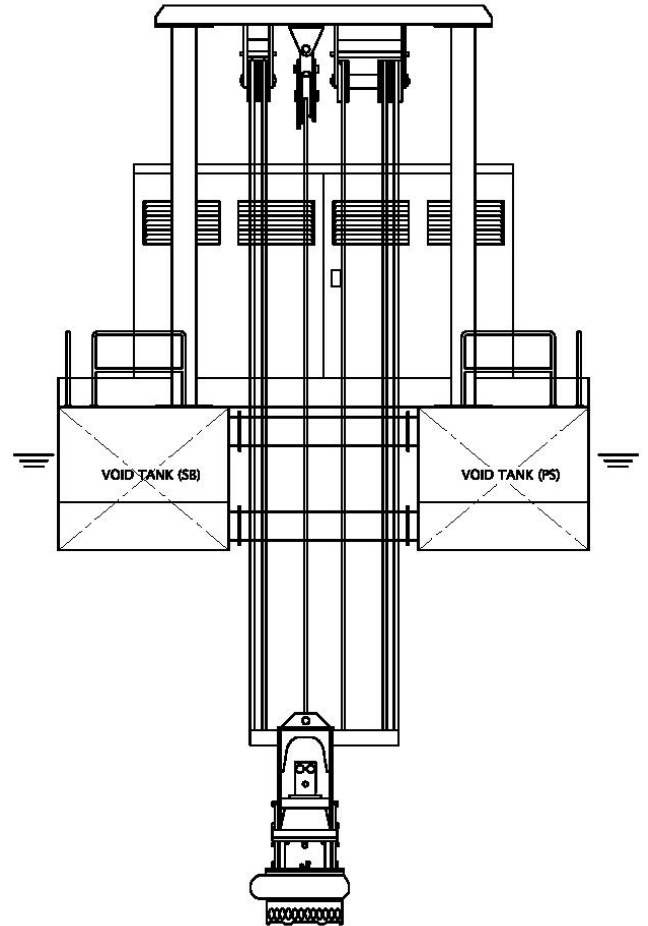
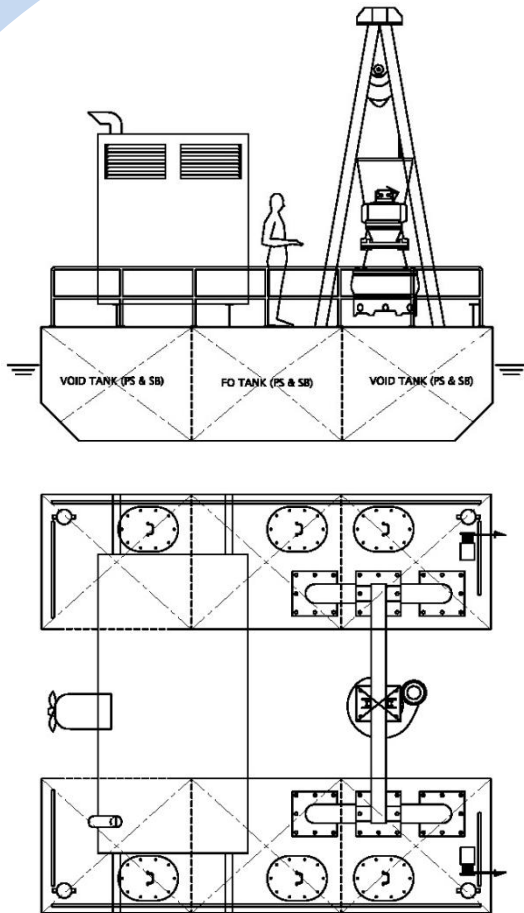

Standard Specification

Max Loaded Weight: 25 ton
 Draft: 1 m
 Length: 6 m
 Breadth: 5.6 m (with 2 section @ 1.8 m)
 Pontoon Height: 1.5 m
 Void Tank: 4 numbers
 Zinc Anode for Cathodic Protection: 10 × 3 kg
 Fuel Capacity: 2 × 4 ton
 Pontoon Nett Weight: 12 ton
 A Frame Winch: 5 ton

Optional Equipment

Hydraulic Pump

- Capacity: up to 900 m³/h
- Head: up to 65 m

 Hydraulic Power Unit
 Hose and Floaters
 Dewatering System
 Railing For Deck Safety
 Statutory Certificate
 Power House Construction
 Hydraulic Winch



www.dredge-pump.com

Email Address: enquiry@dredge-pump.com